

Genetic variation in *Testudo graeca* from Morocco estimated using 12S rRNA sequencing

D. JAMES HARRIS,¹ MOHAMMED ZNARI,²
JEAN-CRISTOPHE MACE³ & MIGUEL ANGEL CARRETERO¹

¹ Centro de Investigação em Biodiversidade e Recursos Genéticos (CIBIO\UP), ICETA,
Campus Agrario de Vairão, 4485-661 Vila do Conde, Portugal
(e-mail: james@mail.icav.up.pt)

² Laboratoire d'Ecologie Animale Terrestre, Département de Biologie,
Faculte des Sciences Samlalia,
B.P. S15, 40001 Marrakech, Morocco

³ Reptilium du Mont Saint-Michel, 62, route du Mont
Saint-Michel-50170, Beauvoir, France

Abstract: Sixteen individuals of *Testudo graeca* from four populations in southern Morocco were sequenced for part of the 12S rRNA mitochondrial gene to determine genetic variation between *T. graeca soussensis* and *T. g. graeca*, and to compare southern with northern populations of *T. g. graeca*. A network was produced including published sequences. Neither *T. g. soussensis* nor *T. whitei* can be distinguished from *T. g. graeca* using this marker. The Moulouya river valley has previously been suggested to separate western and eastern forms, but the western haplotype is also found in Algerian tortoises. The current molecular data support the existence of a single taxonomic unit in North Africa, *T. g. graeca*. Additional detailed morphological and ecological studies are needed to confirm this.

Key words: Morocco, phylogeny, *Testudo graeca*, *Testudo whitei*, 12S rRNA.

Resumen: Variación genética en *Testudo graeca* de Marruecos estimada mediante secuenciación de 12S rRNA. – Parte del gen mitocondrial 12S rRNA fue secuenciado en 16 individuos de *Testudo graeca* pertenecientes a cuatro poblaciones del sur de Marruecos para determinar la variación genética entre *T. graeca soussensis* y *T. g. graeca*, y para comparar poblaciones meridionales y septentrionales de *T. g. graeca*. Se construyó una red que incluía las secuencias publicadas. Ni *T. g. soussensis* ni *T. whitei* pueden distinguirse de *T. g. graeca* utilizando este marcador. Estudios previos sugerían que el valle del río Moulouya separaría las formas occidentales y orientales, pero el haplotipo occidental se encuentra también en tortugas de Argelia. Los datos moleculares disponibles apoyan la existencia de una sola unidad taxonómica en el norte de África, *T. g. graeca*. Para confirmar este extremo son necesarios estudios morfológicos y ecológicos adicionales.

Palabras clave: filogenia, Marruecos, *Testudo graeca*, *Testudo whitei*, 12S rRNA.

INTRODUCTION

Testudo graeca is a terrestrial tortoise with disjunct native populations in northern Africa and southwestern Europe extending into the Middle East and Central Asia. The systematics of this species is uncertain with

many subspecies that are considered as distinct species by some authors (e.g. DAVID, 1994; GMIRA, 1995). Most north African populations are typically referred to the nominal subspecies *Testudo graeca graeca*, although some authors suggest that *T. graeca* from Algeria should be treated as a separate

species, *Testudo whitei* (HIGHFIELD & MARTIN, 1989). Populations are also known from the Iberian Peninsula, although it is not known if these were introduced anthropogenically. Additionally a further subspecies, *Testudo graeca soussensis* has recently been described from the Souss valley in southwest Morocco (PIEH, 2000). A precise assessment of *T. g. graeca* variation is particularly needed as large numbers are still illegally exported from Morocco to Europe every year. Some of those impounded by customs officials are then returned to Morocco (ÁLVAREZ, 2001). If there is genetic subdivision within Morocco, release of these could have a detrimental effect by polluting distinct local gene pools with returned individuals that originated from other areas.

ÁLVAREZ *et al.* (2000) examined mitochondrial DNA sequence data variation between four populations of *T. g. graeca* from northern Morocco and from two populations from Spain. They found a single shared haplotype in all Spanish and some northeastern Moroccan individuals, which could be phylogenetically separated from the northwest Moroccan populations. VAN DER KUYL *et al.* (2002) examined variation both among species of the genus *Testudo* and within *T. graeca* using 12S rRNA sequence data. Samples of the putative *T. whitei* formed a sister group to the *T. g. graeca* sequences. To further examine genetic diversity in Morocco we have extended this analysis by sequencing 16 individuals from four additional populations in southern Morocco, including the terra typica of *T. g. soussensis*.

MATERIALS AND METHODS

Specimens of *T. graeca* were captured from four populations in southern Morocco (Fig. 1). For this analysis four individuals per population were examined. A small piece of



FIGURE 1. Sampling localities of *Testudo graeca graeca* in North Africa and the Iberian Peninsula. Sample sites of the eastern and western forms identified by ÁLVAREZ *et al.* (2000) are indicated by E and W respectively. Four southern populations new for this study are 1: Admine Forest, 2: Essaouira, 3: Central Jbilet Mountains, and 4: Tafarayate.

FIGURA 1. Localidades de muestreo de *Testudo graeca graeca* en el norte de África y en la Península Ibérica. Los lugares de muestreo de las formas orientales y occidentales identificadas por ÁLVAREZ *et al.* (2000) se indican como E y W, respectivamente. Las cuatro poblaciones meridionales nuevas incorporadas en este estudio son 1: Admine Forest, 2: Essaouira, 3: Central Jbilet Mountains, y 4: Tafarayate.

skin was clipped off and stored in ethanol. Live animals were released again in the same capture place. Total genomic DNA was extracted following standard protocols. A 394 bp fragment of the mitochondrial cytochrome 12S rRNA gene was amplified using the primers 12Sa and 12Sb (KOCHER *et al.*, 1989). Thermocycling consisted of 35 cycles of 94°C for 30 seconds, 52°C for 30 seconds and 72°C for 30 seconds. Both strands of the amplified DNA were sequenced on an automated ABI 310 sequencer using a Taq DyeDeoxy™ Terminator Cycle sequencing kit (Perkin Elmer). Unique haplotypes were submitted to GenBank (accession numbers AY775179 and AY775180).

New sequences were aligned against the published sequences (ÁLVAREZ *et al.* 2000; VAN DER KUYL *et al.* 2002), including sequences of *Testudo graeca iberica* and *Testudo whitei*. Within species, bifurcating trees are often not the most appropriate way to represent relationships between haplotypes (reviewed in POSADA & CRANDALL, 2001). Therefore we used the statistical parsimony algorithm (TEMPLETON *et al.*, 1992) performed in TCS (CLEMENT *et al.*, 2000) to estimate a network, with the single base pair deletions included as fifth characters.

RESULTS

In 394 base pairs of 12S rRNA sequences from individuals of *Testudo graeca* we determined nine haplotypes. The most parsimonious network of relationships is shown in Fig. 2. Each haplotype differed

from the next closest by one substitution. Eight variable sites within *T. g. graeca* involved five transitions (two A/G and three C/T), a transversion (C/A), and two single base pair deletions. Individuals from southern Morocco shared one of two haplotypes. All those from the Admine Forest, Essaouira and three of four individuals from Tafrayate had one haplotype. The four individuals from the Central Jbilet Mountains and one individual from Tafrayate had the second haplotype. The sequence of *T. g. iberica* has four substitutions relative to the closest *T. g. graeca* haplotype. However the sample of *T. whitei* is identical to a western Moroccan haplotype.

DISCUSSION

ÁLVAREZ *et al.* (2000) distinguished two genetic entities, a western form and an eastern form, within *T. graeca* in Morocco,

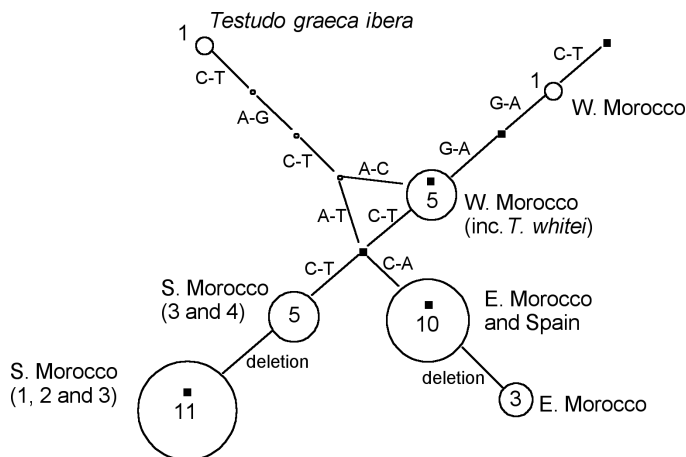

FIGURE 2: Network of relationships of the 12S rRNA sequences from *Testudo graeca graeca*. There are no homoplasic sites. Inferred substitutions and deletions are indicated next to branches. Circle size represents numbers of individuals of known sampling sites with a particular haplotype. Haplotypes from VAN DER KUYL *et al.* (2002), of unknown sampling sites, are indicated by black squares. Dots indicate presumed missing haplotypes between *T. g. iberica* and *T. g. graeca*.

FIGURA 2: Red de relaciones de las secuencias de 12S rRNA de *Testudo graeca graeca*. No hay sitios homóplastos. Las sustituciones y deleciones inferidas se indican junto a las ramas. El tamaño de los círculos representa el número de individuos procedentes de localidades de muestreo conocidas con un determinado haplotipo. Los haplotipos de VAN DER KUYL *et al.* (2002), correspondientes a localidades de muestreo desconocidas, se indican por medio de cuadrados negros. Los puntos indican los presuntos haplotipos ausentes entre *T. g. iberica* y *T. g. graeca*.

separated by the Moulouya river. Our data suggest that southern populations contain haplotypes distinct from these. Haplotypes typically found in southern, western and eastern populations are all reported by VAN DER KUYL *et al.* (2002). Unfortunately the exact localities from which some of these tortoises were collected are unknown (VAN DER KUYL, pers. comm.) and these specimens cannot be used to assess geographic structuring. The Souss valley population (Admine Forest), referred to *T. g. soussensis*, is not distinguishable with this marker from other southern populations of *T. g. graeca*.

Testudo graeca ibera can be clearly separated from all *T. g. graeca* haplotypes. However the degree of differentiation (approximately 1%) is not very high. Typically congeneric Testudine species show higher genetic divergence with this marker, so this result does not give support to a specific status for this taxon.

Testudo whitei is usually considered a synonym of *T. graeca* (e.g. LAMBERT, 1997), but VAN DER KUYL *et al.* (2002) suggest that *T. whitei* forms a clade separate from *T. g. graeca*, and thus warrants subspecific status. In our analysis, the haplotype of *T. whitei* is an internal node within the western Moroccan clade identified by ÁLVAREZ *et al.* (2000).

Genetic variation across the Strait of Gibraltar in reptiles

A focal point of biogeographical studies is the examination of populations of an organism on both sides of a geological barrier, especially one with a known age. The Strait of Gibraltar is a typical example. The Mediterranean Sea dried up during the Messinian salinity crisis, and when the Atlantic breached the Strait circa 5.3 mya it separated the terrestrial fauna. Lack of variation between Spanish and Moroccan populations with 12S rRNA sequencing could indicate

that the Iberian populations were anthropogenically introduced. However recent studies of the reptiles found in both Iberia and northern Africa suggest that gene flow may occur in many species by occasional natural rafting. *Podarcis* wall lizards appear to have crossed the Strait at least twice after its formation (HARRIS *et al.*, 2002). *Emys orbicularis* shows only a single nucleotide substitution between populations in Iberia and in Morocco in over 1000 base pairs of the more variable cytochrome b gene (LENK *et al.*, 1999). This species also seems to have colonised Morocco very recently. The lack of genetic variation in a shorter region of 12S rRNA in *T. g. graeca* does not preclude that some populations in Iberia were not anthropogenically introduced. They may have arrived naturally and relatively recently.

CONCLUSIONS

Based on partial 12S rRNA gene sequences *Testudo g. soussensis* and *T. g. whitei* cannot be distinguished from *T. g. graeca*. While this does not necessarily mean that these populations do not merit subspecific rank, it does not support taxonomic separation either. More detailed morphological and ecological studies and the use of more variable genetic markers, such as microsatellites, will be needed to assess the status of these forms. There is a degree of geographic separation of haplotypes of known localities; the four southern populations all share two haplotypes. However samples assigned to *T. whitei* from Algeria are identical to western Moroccan *T. graeca graeca*, rather than to the geographically closer eastern Moroccan populations, implying that the hypothesis suggesting eastern and western separation along the Moulouya river is overly simplistic.

Acknowledgments

This work was funded by projects from FCT, SFRH/BPD/5702/2001 and POCTI/41912/BSE/2001 as well as by an ICCTI international co-operation award (Portugal-Morocco).

REFERENCES

- ÁLVAREZ, A. (2001): Doscientas tortugas moras son devueltas a Marruecos. *Quercus*, 190: 19.
- ÁLVAREZ, Y., MATEO, J.A., ANDREU, A.C., DÍAZ-PANIAGUA, C., DIEZ, A. & BAUTISTA, J.M. (2000): Mitochondrial DNA haplotyping of *Testudo graeca* on both continental sides of the Strait of Gibraltar. *Journal of Heredity*, 91: 39-41.
- CLEMENT, M., POSADA, D. & CRANDALL, K. A. (2000): TCS: a computer program to estimate gene genealogies. *Molecular Ecology*, 9: 1657-1660.
- DAVID, P. (1994): Liste des reptiles actuels du monde. I. Chelonii. *Dumerilia*, 1: 7-127.
- GMIRA, S. (1993): Nouvelles données sur les espèces actuelles de *Testudo* (Chelonii, Testudinidae). *Bulletin de la Société Herpetologique de France*, 65-66: 49-56.
- HARRIS, D.J., CARRANZA, S., ARNOLD, E.N., PINHO, C. & FERRAND N. (2002): Complex biogeographic distribution of genetic variation within *Podarcis* wall lizards across the Strait of Gibraltar. *Journal of Biogeography*, 29: 1257-1262.
- HIGHFIELD, A.C. & MARTIN, J. (1989): A revision of the Testudines of north Africa, Asia and Europe. Genus: *Testudo*. *Journal of Chelonian Herpetology*, 1: 1-12.
- KOCHER, T.D., THOMAS, W.K., MEYER, A., EDWARDS, S.V., PÄÄBO, S., VILLABLANCA, F.X. & WILSON, A.C. (1989): Dynamics of mitochondrial evolution in animals: amplification and sequencing with conserved primers. *Proceedings of the National Academy of Science USA*, 86: 6196-6200.
- LAMBERT, M.R.K. (1997): *Testudo graeca*. Pp. 176-177, in: Gasc, J. P., Cabela, A., Crnobrnja-Isailovic, J., Dolmen, D., Grossenbacher, K., Haffner, P., Lescure, J., Martens, H., Martínez Rica, J. P., Maurin, H., Oliveira, M. E., Sofianidou, T. S., Veith, M. & Zuiderwijk, A. (eds.), *Atlas of Amphibians and Reptiles in Europe*. Societas Europaea Herpetologica, Paris.
- LENK, P., FRITZ, U., JOGER, U. & WINK, M. (1999): Mitochondrial phylogeography of the European pond turtle, *Emys orbicularis* (Linnaeus 1758). *Molecular Ecology*, 8: 1911-1922.
- PIEH, A. (2000): *Testudo graeca soussensis*, eine neue Unterart der Maurischen Landschildkröte aus dem Sousstal (Südwest-Marokko). *Salamandra*, 36: 209-222.
- POSADA, D. & CRANDALL, K.A. (2001): Intraspecific gene genealogies: trees grafting into networks. *Trends in Ecology and Evolution*, 16: 37-45.
- TEMPLETON, A.R., CRANDALL, K.A. & SING, C.F. (1992): A cladistic analysis of phenotypic associations with haplotypes inferred from restriction endonuclease mapping and DNA sequence data. III Cladogram estimation. *Genetics*, 132: 619-633.
- VAN DER KUYL, A.C., BALLASINA, D.L.P., DEKKER, J.T., MAAS, J., WILLEMSEN, R.E. & GOUDSMIT, J. (2002): Phylogenetic relationships among the species of the genus *Testudo* (Testudines: Testudinidae) inferred from mitochondrial 12S rRNA gene sequences. *Molecular Phylogenetics and Evolution*, 22: 174-183.

ms # 164
 Recibido: 01/03/02
 Aceptado: 23/09/03